

NOTES: UNLESS OTHERWISE SPECIFIED

1. SEE DRAWING NO. CB-00281 AND PROCEDURE P-1000 FOR ASSEMBLY AND TEST INSTRUCTION. PROCEDURES AND ASSEMBLY DRAWING ARE FOR INTERNAL USE ONLY.
2. ALL TESTING IS PERFORMED IAW BATTERY COUNCIL INTERNATIONAL STANDARDS.
3. ALL DIMENSIONS ARE IN INCHES [MM]
4. ABBREVIATION USED IN TITLE IS: SEALED LEAD ACID
5. TERMINAL HARDWARE KIT PROVIDED, PART NUMBER 6923

| REVISIONS | | | |
|-----------|--|---------|----------|
| REV | DESCRIPTION | DATE | APPROVED |
| A | CHANGED HANDLE DIRECTION | 2/26/07 | JBT |
| B | CHANGED COVER & HANDLE, NOM. WT. 94 lbs WAS 85 lbs | 11/6/07 | JBT |

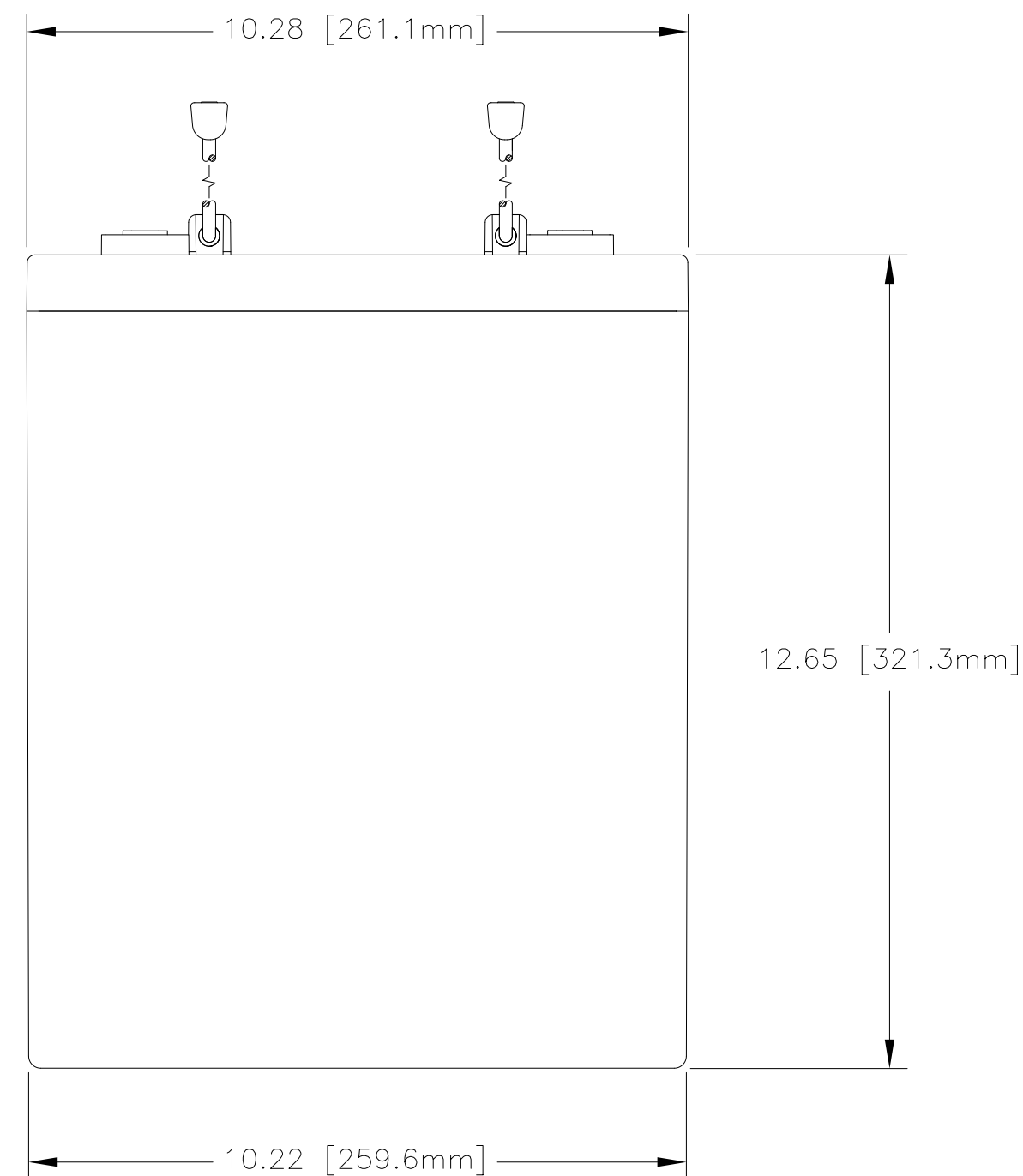
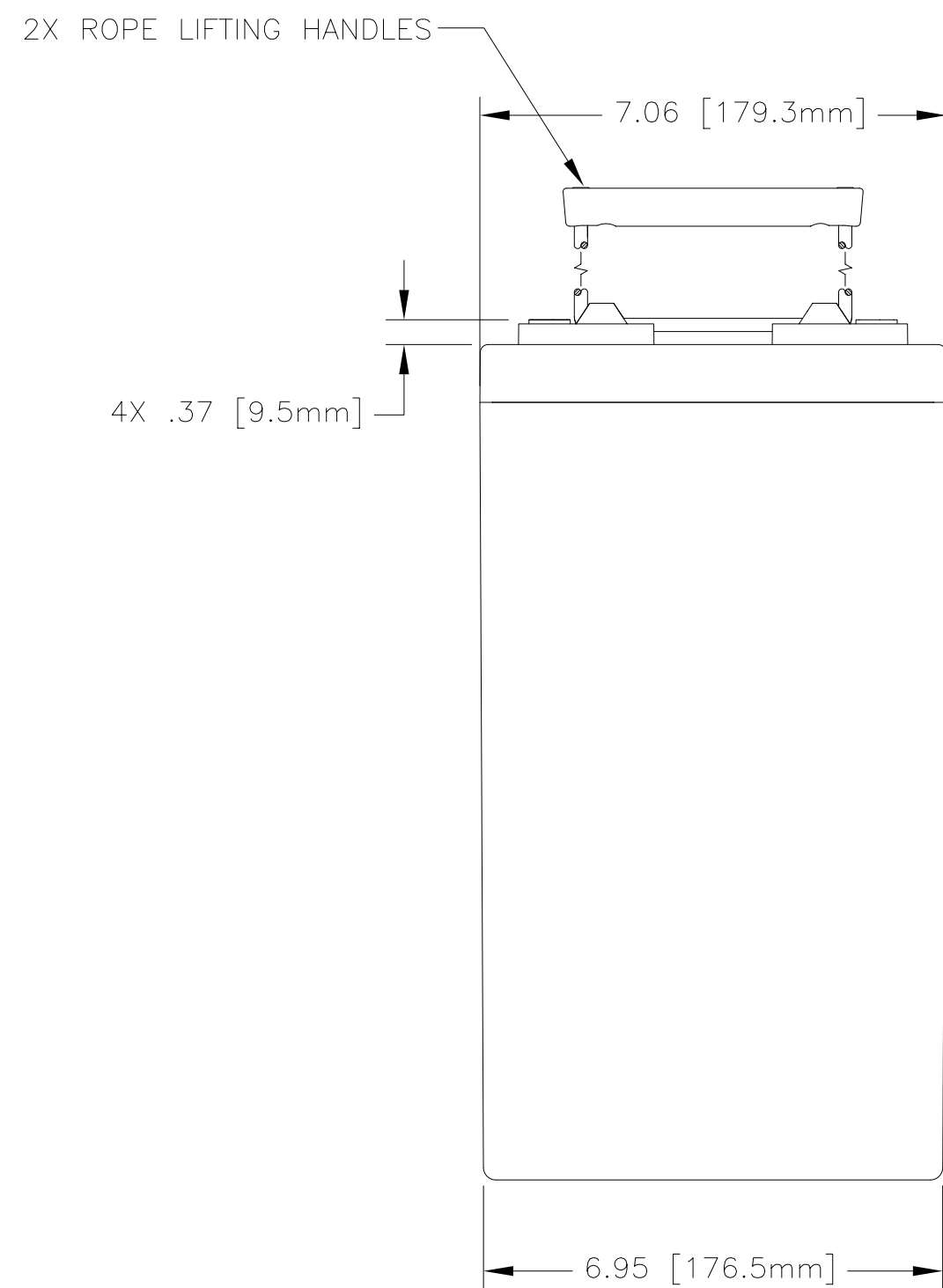
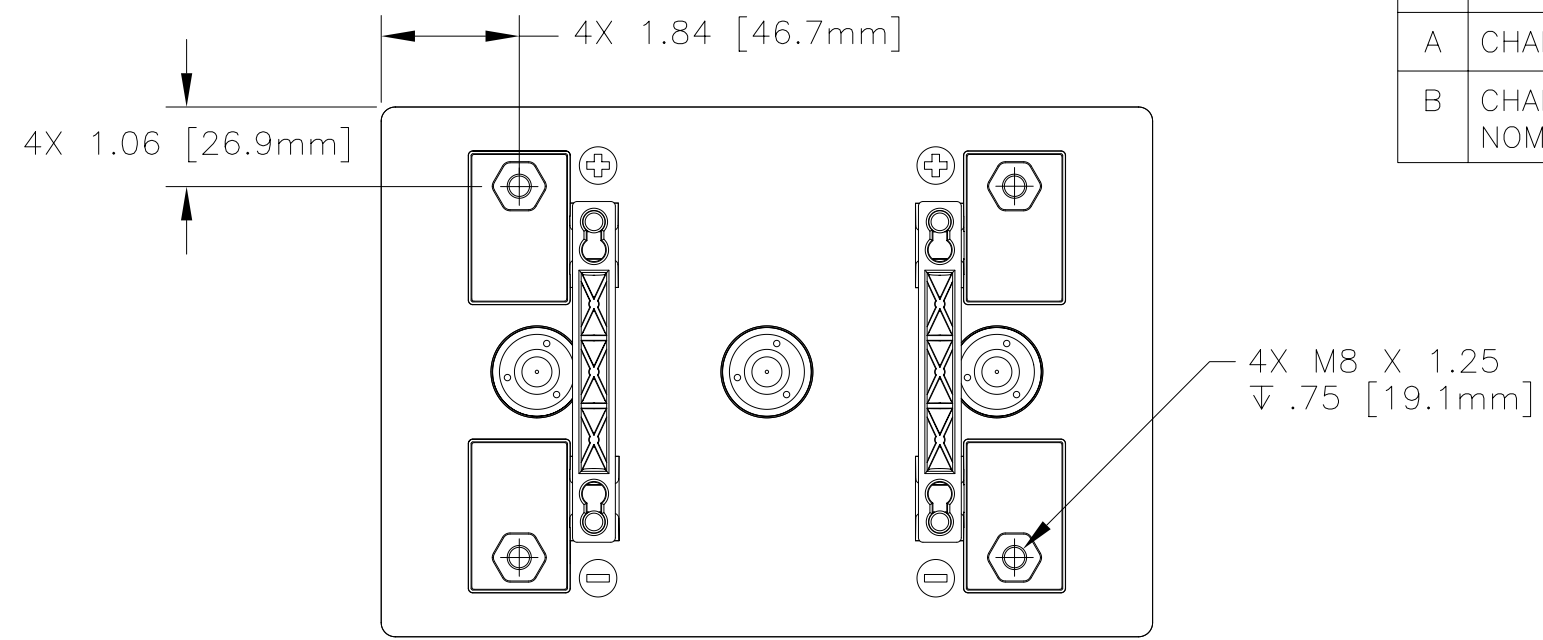

ENVELOPE DRAWING

| CAPACITY RATINGS | |
|--|------------------|
| PART NUMBER | PVX-9150T |
| NOMINAL WEIGHT | 94 LBS [42.6 KG] |
| AMPERE HOUR CAPACITY @ 24 HOUR 1.75 VOLTS/CELL @ 77°F (25° C) | 915 AH |

| QTY | REQD | CAGE CODE | PART OR IDENTIFYING NO. | NOMENCLATURE OR DESCRIPTION | MATERIAL SPECIFICATION | ITEM NO. |
|--|------|-----------|-------------------------|---|------------------------|------------------------------------|
| PARTS LIST | | | | | | |
| UNLESS OTHERWISE SPECIFIED DIMENSIONS ARE IN INCHES TOLERANCES ARE: FRACTIONS DECIMALS ANGLES ± 1/32 .XX ± .12 ± 1° .XXX ± .060 | | | | CONCORDE BATTERY CORPORATION 2009 SAN BERNARDINO RD, W. COVINA, CA 91790 | | |
| TREATMENT NONE | | | | APPROVALS | DATE | TITLE |
| FINISH NONE | | | | DRAWN D. AYALA | 12/15/06 | BATTERY, SLA, 2 VOLT, PVX-9150T |
| SIMILAR TO N/A | | | | CHECKED AMIII | 1/5/07 | SIZE C |
| ACT WT N/A | | | | APPROVED JBT | 1/8/07 | CAGE CODE 63017 |
| CALC WT N/A | | | | ISSUED NS | 11/29/07 | DWG NO. PVX-9150T |
| | | | | SCALE 1=2.5 | | REV B |
| | | | | | | SHEET 1 OF 1 |